

NX58F5700WS

Gas Range

Features

- Large 5.8 cu. ft. Oven Capacity
- 57K BTU Total Power, including an 18K BTU dual-power burner and 5K BTU simmer
- Griddle and Wok Grate Included
- Continuous Matte Grates
- Stainless steel cooktop and membrane design
- True Convection for Even Cooking
- Gliding Rack for Easy Access to Food in the Oven
- Weighted Stainless Knobs
- Warming Drawer
- Premium Big View Window Design

Convenience

- Auto Oven Light
- Kitchen Timer
- Delay Start
- Auto Shut-Off Option
- Child Safety Lock
- Self Clean
- 4 Easy Cook Presets
- LP conversion kit included



Five Burner Cooktop



Custom Griddle and Wok Grate

Available Color



Stainless Steel

Signature Features



Five Burner Cooktop

FIVE BURNERS FOR ULTIMATE FLEXIBILITY

- Enjoy the flexibility to cook with different-sized pans simultaneously.
- Whether you're boiling water, melting chocolate or simmering sauce, there's a burner for your needs.
- Dual power burner features independent heating elements ranging from 18K BTU to 600 BTU, allowing you to go from a rapid boil to a true simmer.
- Oval burner used for oversized pots or pans, or "bridge" cooking.



Griddle and Wok Grate

GRIDDLE AND WOK GRATE, CUSTOM-MADE FOR YOUR RANGE

- Cook a variety of breakfast foods or grilled sandwiches at once on the removable stove-top griddle.
- Easily accommodate a round bottom wok on the custom wok grate.
- Griddle and wok grate are included with purchase.



True Convection

COOK FOOD FASTER AND MORE EVENLY

- Heated fan system is great for baking and broiling because temperature is distributed thoroughly and food cooks evenly.
- Enjoy tastier results each time.

SAMSUNG

NX58F5700WS

Gas Range

Installing Your Range

30" minimum clearance between the top of the cooking surface and the bottom of an unprotected wood or metal cabinet; or 24" minimum when the bottom of the wood or metal cabinet is protected by not less than 1/4" flame retardant millboard covered with not less than no.28 MSG sheet steel, 0.015" stainless steel, 0.024" aluminum or 0.020" copper.

** 18" minimum between the countertop and the adjacent cabinet bottom.

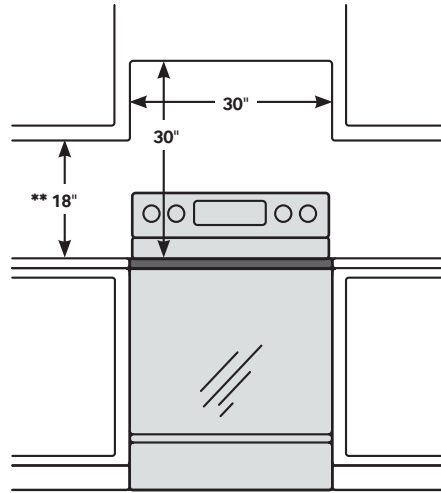

IMPORTANT: To eliminate the risk of burns or fire caused by reaching over heated surface units, cabinet storage space located above the surface units should be avoided. If cabinet storage is to be provided, the risk can be reduced by installing a range hood that projects horizontally a minimum of 5" beyond the bottom of the cabinets.

Dimensions

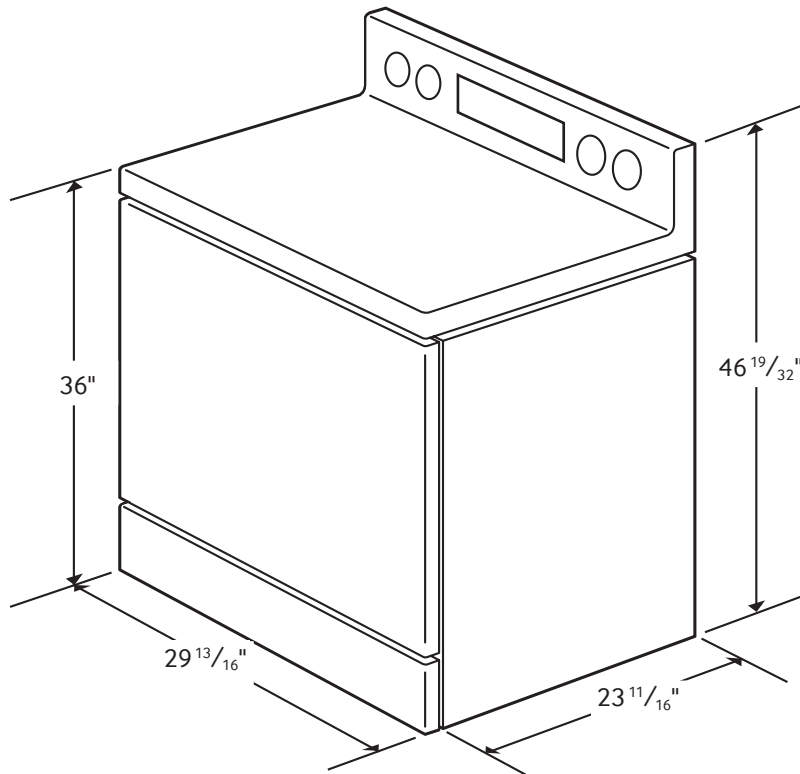

Total Power (BTU)
57K

Stainless Steel Cooktop with 5 Burners (BTU)

- Right Front: 18K (Dual)
- Left Front: 15K
- Right Rear: 5K
- Left Rear: 9.5K
- Center (Oval): 9.5K

Oven

- True Convection
- Capacity: 5.8 cu. ft.
- Bake: 150°F - 550°F
- Convection Bake: 302°F - 550°F
- Convection Roast: 302°F - 550°F
- Variable Broil: 375°F - 480°F

Warming Drawer

- Capacity: 0.7 cu. ft.
- Temperature Settings: High, Medium, Low

Warranty

One (1) Year All Parts and Labor

Product Dimensions & Weight (WxHxD)

Outside Dimensions:
29¹³/₁₆" x 46¹⁹/₃₂" x 23¹¹/₁₆"

Weight: 198 lbs.

Shipping Dimensions & Weight (WxHxD)

Dimensions:
32⁷/₈" x 50⁹/₁₆" x 30¹/₈"

Weight: 231 lbs.

Color	Model #	UPC Code
Stainless Steel	NX58F5700WS	887276986739

SAMSUNG